

BUD INDUSTRIES, INC.

QUALITY ENCLOSURES

Home Product Catalog Representatives Search
 Company Info Distributors What's New

[Get A Quote](#)



Accessories - Fan Tray
Fan Tray / Fan Assy



[Click on Image for Larger View](#)

Fan Tray / Fan Assemblies are completely assembled with fans and ready to use. Just position them in place and plug them in. Available in 3, 6, or 9 fan versions to meet most applications.

Design Features

- Standard EIA 19" panel width and 1-U (1.75") high
- Illuminated on/off switch conveniently located on the front panel
- 115VAC, 60Hz operation
- Additional support brackets included with 6 and 9 fan versions
- 7ft. long power cord



Fan Tray / Fan Assy					
Catalog Number	Drawings	Number of Fans	Total CFM	Overall Size H x W x D	Weight Lbs.
FT-1973	PDF DXF	3	315	1.75" x 19" x 7.00"	11

FT-1976	PDF DXF	6	630	1.75" x 19" x 12.00"	21
FT-1979	PDF DXF	9	945	1.75" x 19" x 17.25"	31

[DXF](#) Autocad DXF Specifications File
(Requires CAD software such as AutoCAD)

[PDF](#) Adobe PDF Specifications File



[Download PDF Viewer](#)

Get A Quote

[Home](#) | [Company Info](#) | [Online Catalog](#) | [Check Stock](#) | [Distributor/Price](#)

[Reps](#) | [New](#) | [Search](#) | [Contact](#) | [Privacy Policy](#)

BUD INDUSTRIES INC.

P.O. Box 998

Willoughby, Ohio 44094

Phone: 440-946-3200 Fax: 440-951-4015

E-Mail: saleseast@budind.com

PART NAME

FAN TRAY ASSEMBLY (3) FANS

PART No.

FT-1973

REV. DATE

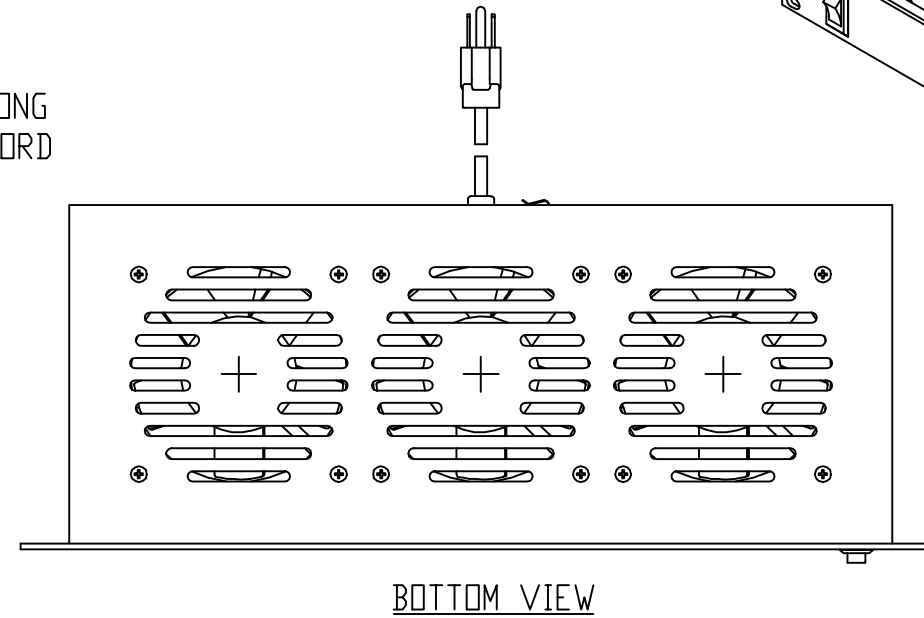
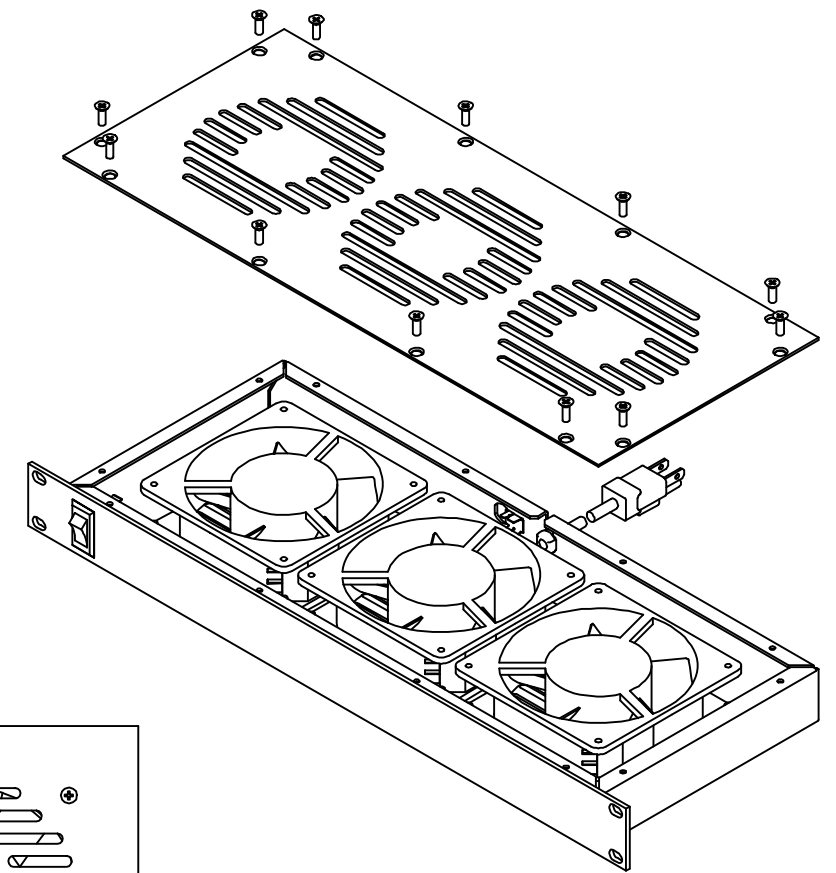
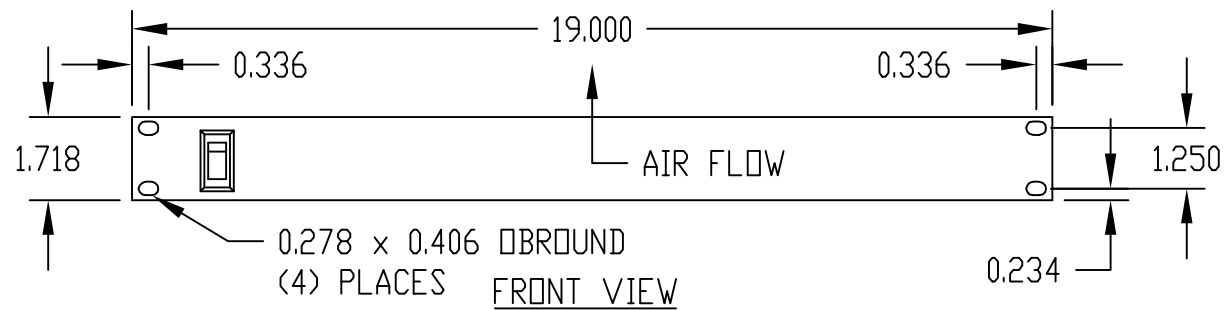
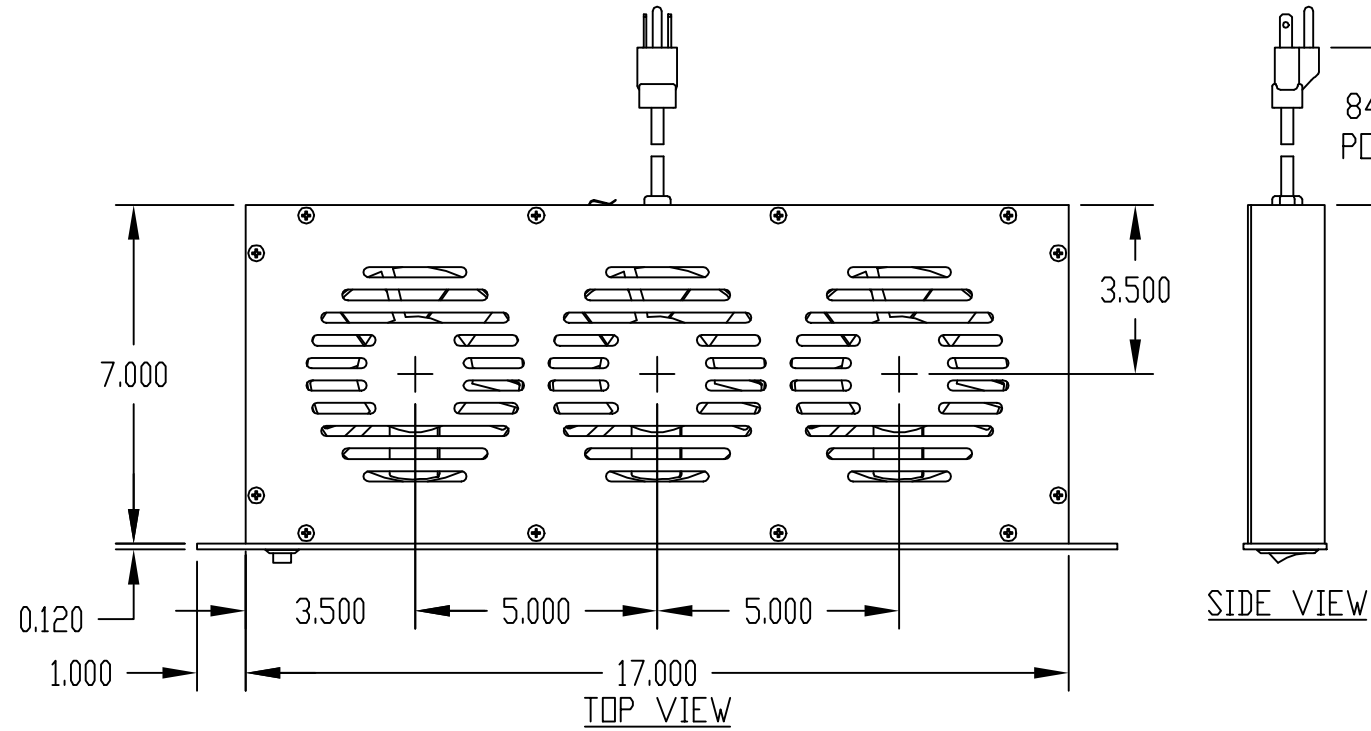
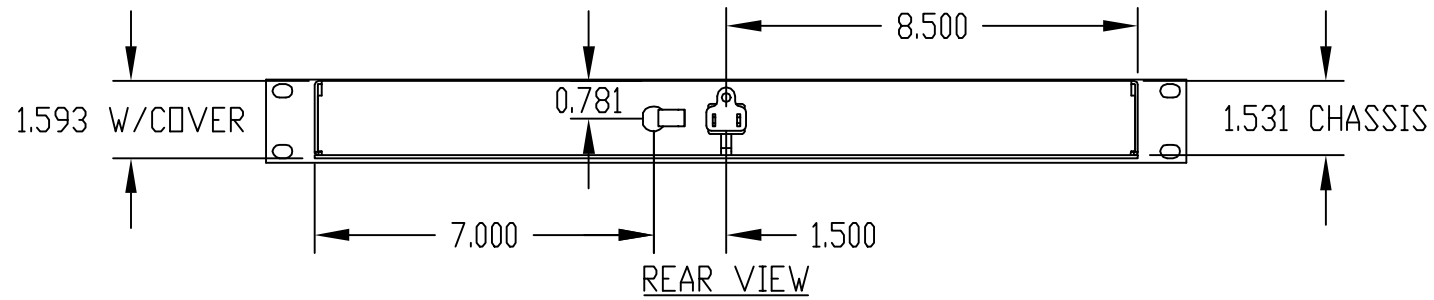

MATERIAL:

CHASSIS & COVER _____ 16 GA. STEEL
 FRONT PANEL _____ 11 GA. STEEL

FINISH: SMOOTH BLACK

UNIT SUPPLIED FULLY ASSEMBLED.

FAN HOUSING: ONE-PIECE ZINC DIE CASTING
 IMPELLER: THERMOPLASTIC (UL-94-V0)

POWER	CFM	WATTS	TEMP. RANGE
115 V.A.C.	105	19/17	-20°C. TO +60°C.